

Slotted & Unslotted Hex Washer
With & Without Serrations

SELF-PIERCING

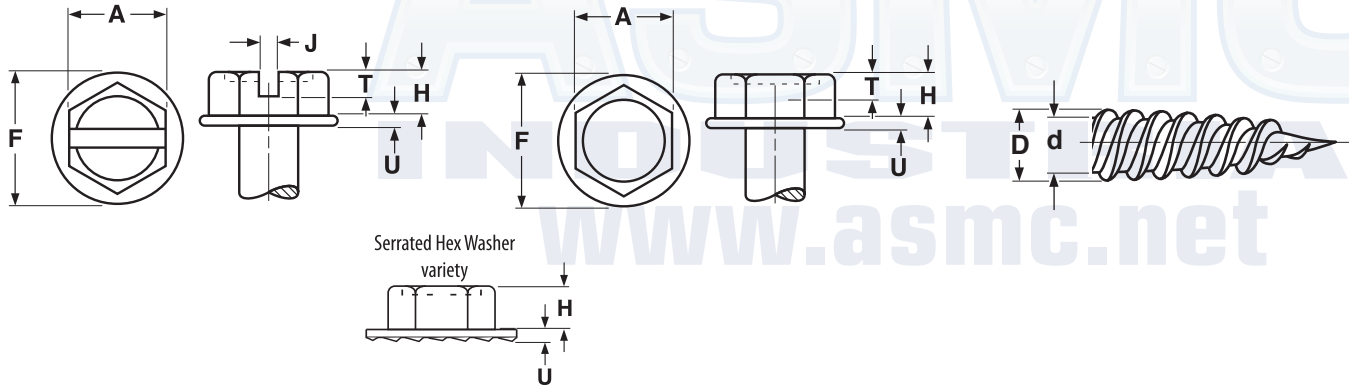

HEX WASHER HEAD SELF-PIERCING SCREWS

Size	A		H		F		U		J		T		D		d	
	Width Across Flats		Head Height		Washer Diameter		Washer Thickness		Slot Width		Slot Depth		Major Diameter		Minor Diameter	
	Max	Min	Max	Min	Max	Min	Max	Min	Max	Min	Max	Min	Max	Min	Max	Min
6-18	.250	.244	.093	.080	.328	.302	.025	.015	.048	.039	.053	.033	.141	.136	.102	.096
7-16	.250	.244	.093	.080	.328	.302	.029	.017	.048	.039	.062	.040	.158	.152	.114	.108
8-15	.250	.244	.110	.096	.348	.322	.031	.019	.054	.045	.074	.052	.168	.162	.123	.116
10-12	.250	.244	.110	.096	.414	.384	.031	.019	.054	.045	.074	.052	.194	.188	.133	.126
	.312	.305	.120	.105	.414	.384	.031	.019	.060	.050	.074	.052	.194	.188	.133	.126
10-16	.250	.244	.110	.096	.414	.384	.031	.019	.054	.045	.074	.052	.194	.188	.133	.126
	.312	.305	.120	.105	.414	.384	.031	.019	.060	.050	.074	.052	.194	.188	.133	.126
12-11	.312	.305	.150	.133	.432	.398	.039	.022	.067	.056	.093	.077	.221	.215	.162	.155
14-10	.375	.366	.190	.171	.520	.479	.050	.029	.075	.064	.111	.082	.254	.247	.200	.178
Tolerance on Length								±0.05								

NOTE: There is no single standard for self-piercing screw dimensions. These values are offered as a guide; deviations from these specifications may occur.

Description	A hex washer head thread forming tapping screw with a single lead thread rolled to the tip of an extra sharp point, and a second thread spaced 180° apart. Head can be slotted or unslotted. The bearing surface of the washer is sometimes ordered with serrations.	
Applications/ Advantages	May be used in thin metal (less than .050 thick). Eliminates need for pre-drilled or pre-punched holes. Undercut area beneath the head allows greater length of thread engagement. Twin lead threads help to reduce driving torque.	The 18-8 variety offers greater corrosion resistance than the zinc-plated steel screw, but since it is not hardenable, its tip cannot puncture as wide a range of metals. The 410 stainless screw is more corrosion-resistant than a steel screw but less than the 18-8. Since the 410 screw is hardenable, it can pierce a wider variety of metals than the 18-8 type, but can become brittle in low temperatures.
Material	AISI 1018 - 1022 or equivalent steel	18-8 or 410 stainless
Heat Treatment	Screws shall be quenched in liquid and then tempered by reheating to 650°F minimum.	410 stainless screws shall be hardened and tempered by heating to 1800-1900°F sufficient for austenization, held for at least 1/2 hour and rapid air or oil-quenched, then reheating to 500-600°F for at least 1 hour and air cooled to provide the specified hardness.
Surface Hardness	Rockwell C45 minimum	410 SS: Rockwell C55 minimum
Case Depth	No. 6 diameter: .002 - .007 No. 7 thru 12 diameter: .004 - .009 1/4" diameter: .005 - .011	
Core Hardness (after tempering)	Rockwell C28 - 38	410 SS: Rockwell C38 - 42 (after tempering)
Plating	See Appendix-A for plating information.	Stainless self-piercing screws are usually supplied plain.