

Hex Washer Combo
Hex Washer Square

HEAD DIMENSIONS

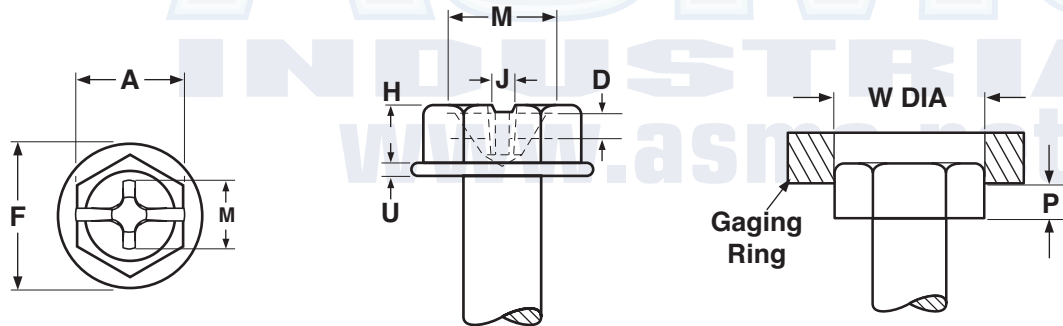

| COMBINATION HEX WASHER HEADS | | | | | | | | | | | | | | | | | ASME B18.6.3- 2013 | |
|------------------------------|--------------------|------|-------------|------|-----------------|------|------------------|------|------------|------|------------|------|-------------------------------|-----------------|---------------------------------|------|----------------------|--|
| Nom Size | A | | H | | F | | U | | J | | D | | P | M | Recess Penetrating Gaging Depth | | Phillips Driver Size | |
| | Width Across Flats | | Head Height | | Washer Diameter | | Washer Thickness | | Slot Width | | Slot Depth | | Protrusion Beyond Gaging Ring | Recess Diameter | Max | Min | | |
| | Max | Min | Max | Min | Max | Min | Max | Min | Max | Min | Max | Min | Min | Ref | | | | |
| 6 | .250 | .244 | .093 | .080 | .328 | .302 | .025 | .015 | .048 | .039 | .053 | .033 | .048 | .148 | .089 | .064 | 2 | |
| 8 | .250 | .244 | .110 | .096 | .348 | .322 | .031 | .019 | .054 | .045 | .074 | .052 | .058 | .168 | .115 | .090 | 2 | |
| 10 | .312 | .305 | .120 | .105 | .414 | .384 | .031 | .019 | .060 | .050 | .080 | .057 | .063 | .178 | .127 | .102 | 2 | |
| 12 | .312 | .305 | .155 | .139 | .432 | .398 | .039 | .022 | .067 | .056 | .103 | .077 | .083 | .247 | .152 | .127 | 3 | |
| 1/4 | .375 | .367 | .190 | .172 | .520 | .480 | .050 | .030 | .075 | .064 | .111 | .083 | .103 | .277 | .186 | .161 | 3 | |

www.asmc.net

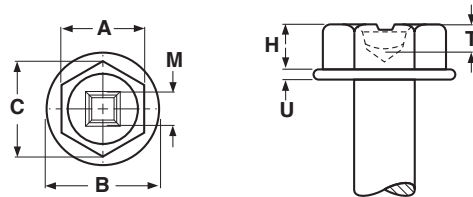

| SQUARE RECESS HEX WASHER HEADS | | | | | | | | | | | | | |
|--------------------------------|--------------------|------|----------------------|-------------|------|-----------------|------|------------------|------|-----------------|---------------------------------|------|--------------------|
| Nominal Size | A | | C | H | | B | | U | | M | T | | Square Recess Size |
| | Width Across Flats | | Width Across Corners | Head Height | | Washer Diameter | | Washer Thickness | | Recess Diameter | Recess Penetration Gaging Depth | | |
| | Max | Min | Min | Max | Min | Max | Min | Max | Min | Ref | Max | Min | |
| 8 | .250 | .244 | .272 | .110 | .096 | .348 | .322 | .031 | .019 | .168 | .085 | .060 | 1 |

INDUSTRIAL
www.asmc.net