

**WASHERS** Countersunk Finishing, Stainless

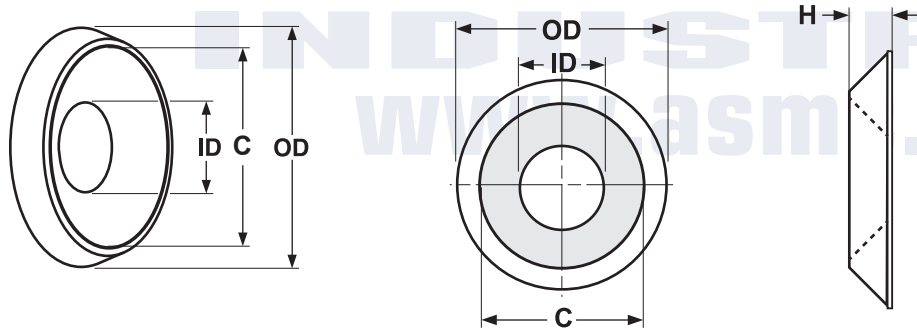

METRIC 90° COUNTERSUNK FINISHING WASHERS				
Screw Size	OD	ID	C	H
	Outside Diameter	Inside Diameter	Cup Diameter	Overall Height
	Max	Min	Min	Min
M3	9	3.5	6.5	2
M4	11	4.5	8	2.5
M5	14	5.5	10	3
M6	16	7	12	3.5
M8	22	9	16	4.5

<b>Description</b>	A formed circular washer designed for use with metric flat or oval head screws. This is a raised type of finishing washer that is convex shaped.
<b>Applications / Advantages</b>	Designed for accommodating the heads of countersunk screws. It provides additional bearing area on the material being fastened and provides a neat, finished appearance.
<b>Material</b>	A2 or A4 Stainless Steel