

THREAD FORMING SCREWS

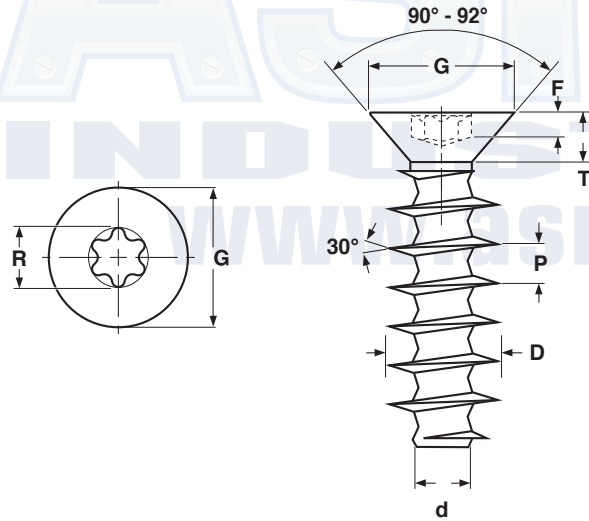

METRIC - TYPE PT®-ALTERNATIVE THREAD FORMING SCREWS, FLAT 6-LOBE										
Screw Size	P	D		d	G		T	R	F	Drive Size
	Thread Dimensions				Head Dimensions			Recess Dimensions		
	Thread Pitch	External Thread Diam.		Thread Core	Diameter		Height	Diameter	Gauge Penetration	
	Ref	Max	Min	Ref	Max	Min	Ref	Max	Min	
M1.6	0.67	1.74	1.60	0.95	3.00	2.75	0.96	1.47	0.40	T5
M2	0.89	2.14	2.00	1.15	3.80	3.53	-	1.75	0.50	T6
M2.2	0.98	2.34	2.20	1.25	3.80	3.53	1.20	1.75	0.70	T6
M2.5	1.12	2.64	2.50	1.40	4.70	4.43	1.70	2.40	0.80	T8
M3	1.34	3.14	3.00	1.66	5.50	5.23	1.80	2.40	0.80	T8
M3.5	1.57	3.68	3.50	1.91	7.30	6.97	2.50	3.35	1.00	T15
M4	1.79	4.18	4.00	2.17	8.40	8.07	2.90	3.95	1.25	T20
M5	2.24	5.18	5.00	2.68	9.30	8.97	-	3.95	1.25	T20
Tolerance on Length					3 ~ 6mm: ± 0.30 mm			7 ~ 10mm: ± 0.40 mm		
					11 ~ 30mm: ± 0.50 mm			31 ~ 80mm: ±0.65 mm		

Description	A spaced thread fastener with a countersunk head, having a flat top surface and a cone-shaped bearing surface with a head angle of approximately 90°. When compared to a Plastite®-alternative thread rolling screw, the PT®-alternative threads are wider and have a sharper angle. Furthermore, the core of the shank has a reduced diameter between each consecutive set of threads. The point opposite the head is blunt.	
Applications/ Advantages	Designed to form its own thread in thermoplastic materials. The 30° thread angle reduces the outward expansion of the material being displaced. The recessed design of the thread root enables more material to flow into the area between threads. The depth of the thread pattern increases the fastener's load carrying properties while resisting vibrations, thus resisting loosening.	
Material	Steel Diameter M3 & smaller: Case-Hardened C1022 Steel Diameters M3.5 and larger: Through-hardened C1022 Steel	Stainless A2 Stainless Steel
Core Hardness	HV 270 - 390	
Surface Hardness	HV 450 min.	