

Serrated External Tooth Lockwasher

WASHERS

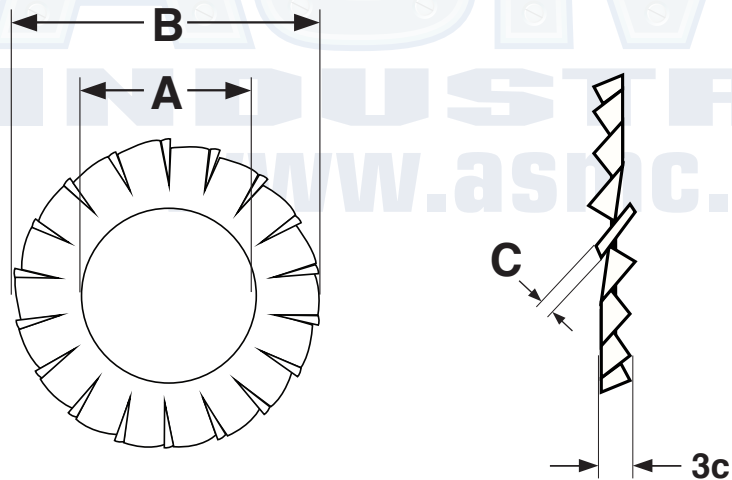

METRIC - SERRATED EXTERNAL TOOTH (TYPE A) LOCKWASHERS						DIN 6798
Nominal Size	A		B		C	Minimum Number of Teeth
	Inside Diameter		Outside Diameter		Material Thickness	
	Max	Min (Nominal)	Max (Nominal)	Min	Ref	
M3	3.38	3.2	6	5.7	0.4	9
M4	4.48	4.3	8	7.64	0.5	11
M5	5.58	5.3	10	9.64	0.6	11
M6	6.62	6.4	11	10.57	0.7	12
M8	8.62	8.4	15	14.57	0.8	14

<b>Description</b>	A "soft" stainless circular washer with twisted prongs or "teeth" which extend out from the outer edge of the washer.
<b>Applications/ Advantages</b>	The serrated variety of external tooth lockwasher is preferred when used in areas where access would be limited after the screw or bolt has been fitted in place. The design of the teeth provides a high amount of friction and evenly distributed torque against the mating surface.
<b>Material</b>	A2 Stainless Steel
<b>Hardness</b>	-
<b>Plating</b>	Stainless washers are usually provided without additional finish.